



STS1HNK60

N-CHANNEL 600V - 8Ω - 0.3A SO-8
SuperMESH™ Power MOSFET

TYPE	V _{DSS}	R _{DS(on)}	I _D	P _w
STS1HNK60	600 V	< 8.5 Ω	0.3 A	2 W

- TYPICAL R_{DS(on)} = 8 Ω
- EXTREMELY HIGH dv/dt CAPABILITY
- 100% AVALANCHE TESTED
- GATE CHARGE MINIMIZED
- NEW HIGH VOLTAGE BENCHMARK

DESCRIPTION

The SuperMESH™ series is obtained through an extreme optimization of ST's well established strip-based PowerMESH™ layout. In addition to pushing on-resistance significantly down, special care is taken to ensure a very good dv/dt capability for the most demanding applications. Such series complements ST full range of high voltage MOSFETs including revolutionary MDmesh™ products.

APPLICATIONS

- SWITCH MODE LOW POWER SUPPLIES (SMPS)
- LOW POWER, LOW COST CFL (COMPACT FLUORESCENT LAMPS)
- LOW POWER BATTERY CHARGERS

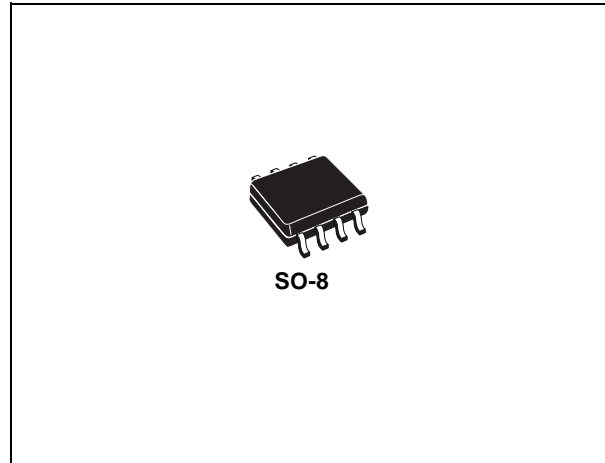

SO-8

INTERNAL SCHEMATIC DIAGRAM

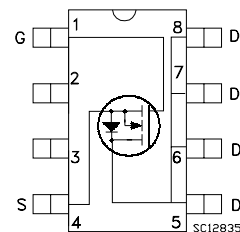

ORDERING INFORMATION

SALES TYPE	MARKING	PACKAGE	PACKAGING
STS1HNK60	S1HNK60	SO-8	TAPE & REEL

STS1HNK60

ABSOLUTE MAXIMUM RATINGS

Symbol	Parameter	Value	Unit
V _{DS}	Drain-source Voltage (V _{GS} = 0)	600	V
V _{DGR}	Drain-gate Voltage (R _{GS} = 20 kΩ)	600	V
V _{GS}	Gate- source Voltage	± 30	V
I _D	Drain Current (continuous) at T _C = 25°C	0.3	A
I _D	Drain Current (continuous) at T _C = 100°C	0.19	A
I _{DM} (•)	Drain Current (pulsed)	1.2	A
P _{TOT}	Total Dissipation at T _C = 25°C	2	W
	Derating Factor	0.016	W/°C
dv/dt (1)	Peak Diode Recovery voltage slope	3	V/ns
T _j T _{stg}	Operating Junction Temperature Storage Temperature	-65 to 150	°C

(•) Pulse width limited by safe operating area

(1) I_{SD} ≤ 0.3A, di/dt ≤ 100A/μs, V_{DD} ≤ V_{(BR)DSS}, T_j ≤ T_{JMAX}.

THERMAL DATA

R _{thj-amb}	Thermal Resistance Junction-ambient Max	62.5	°C/W
----------------------	---	------	------

ELECTRICAL CHARACTERISTICS (T_{CASE} = 25°C UNLESS OTHERWISE SPECIFIED)

ON/OFF

Symbol	Parameter	Test Conditions	Min.	Typ.	Max.	Unit
V _{(BR)DSS}	Drain-source Breakdown Voltage	I _D = 1 mA, V _{GS} = 0	600			V
I _{DSS}	Zero Gate Voltage Drain Current (V _{GS} = 0)	V _{DS} = Max Rating V _{DS} = Max Rating, T _C = 125 °C			1 50	μA μA
I _{GSS}	Gate-body Leakage Current (V _{DS} = 0)	V _{GS} = ± 30 V			±100	nA
V _{GS(th)}	Gate Threshold Voltage	V _{DS} = V _{GS} , I _D = 250 μA	2.25	3	3.7	V
R _{DS(on)}	Static Drain-source On Resistance	V _{GS} = 10 V, I _D = 0.5 A		8	8.5	Ω

ELECTRICAL CHARACTERISTICS (CONTINUED)

DYNAMIC

Symbol	Parameter	Test Conditions	Min.	Typ.	Max.	Unit
g_{fs} (1)	Forward Transconductance	$V_{DS} > I_{D(on)} \times R_{DS(on)max}$, $I_D = 0.5 \text{ A}$		1		S
C_{iss} C_{oss} C_{rss}	Input Capacitance Output Capacitance Reverse Transfer Capacitance	$V_{DS} = 25\text{V}$, $f = 1 \text{ MHz}$, $V_{GS} = 0$		156 23.5 3.8		pF pF pF

SWITCHING ON

Symbol	Parameter	Test Conditions	Min.	Typ.	Max.	Unit
$t_{d(on)}$ t_r	Turn-on Delay Time Rise Time	$V_{DD} = 300 \text{ V}$, $I_D = 0.5 \text{ A}$ $R_G = 4.7\Omega$, $V_{GS} = 10 \text{ V}$ (Resistive Load see, Figure 3)		6.5 5		ns ns
Q_g Q_{gs} Q_{gd}	Total Gate Charge Gate-Source Charge Gate-Drain Charge	$V_{DD} = 480 \text{ V}$, $I_D = 1 \text{ A}$, $V_{GS} = 10\text{V}$, $R_G = 4.7\Omega$		7 1.1 3.4	10	nC nC nC

SWITCHING OFF

Symbol	Parameter	Test Conditions	Min.	Typ.	Max.	Unit
$t_{d(off)}$ t_f	Turn-off Delay Time Fall Time	$V_{DD} = 300 \text{ V}$, $I_D = 0.5 \text{ A}$ $R_G = 4.7\Omega$, $V_{GS} = 10 \text{ V}$ (Resistive Load see, Figure 3)		19 25		ns ns
$t_{r(voff)}$ t_f t_c	Off-voltage Rise Time Fall Time Cross-over Time	$V_{DD} = 480\text{V}$, $I_D = 1.0 \text{ A}$, $R_G = 4.7\Omega$, $V_{GS} = 10\text{V}$ (Inductive Load see, Figure 5)		24 25 44		ns ns ns

SOURCE DRAIN DIODE

Symbol	Parameter	Test Conditions	Min.	Typ.	Max.	Unit
I_{SD} I_{SDM} (2)	Source-drain Current Source-drain Current (pulsed)				0.3 1.2	A A
V_{SD} (1)	Forward On Voltage	$I_{SD} = 0.3 \text{ A}$, $V_{GS} = 0$			1.6	V
t_{rr} Q_{rr} I_{RRM}	Reverse Recovery Time Reverse Recovery Charge Reverse Recovery Current	$I_{SD} = 0.3 \text{ A}$, $di/dt = 100 \text{ A}/\mu\text{s}$ $V_{DD} = 25 \text{ V}$, $T_j = 150^\circ\text{C}$ (see test circuit, Figure 5)		229 377 3.3		ns μC A

Note: 1. Pulsed: Pulse duration = 300 μs , duty cycle 1.5 %.
2. Pulse width limited by safe operating area.

Safe Operating Area

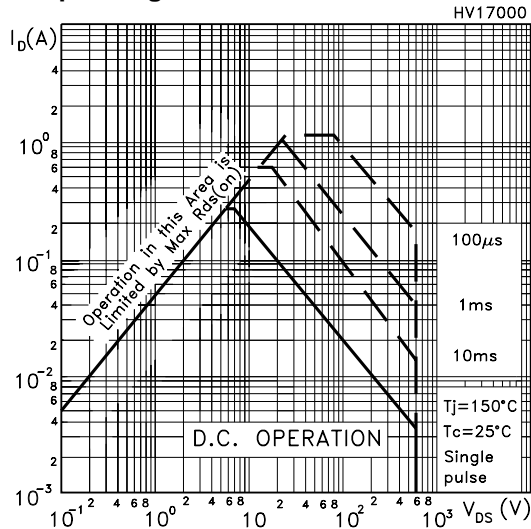

Thermal Impedance

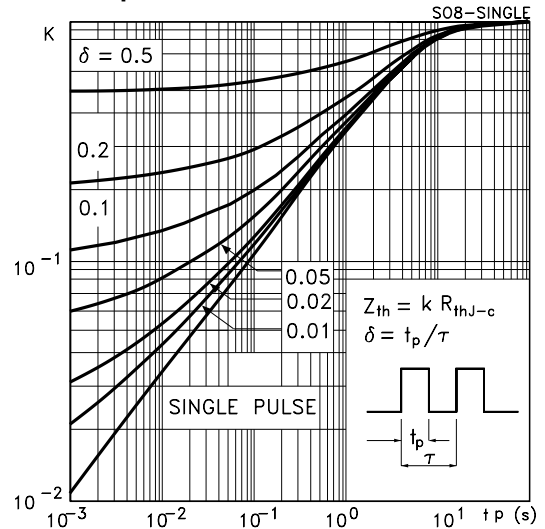

Output Characteristics

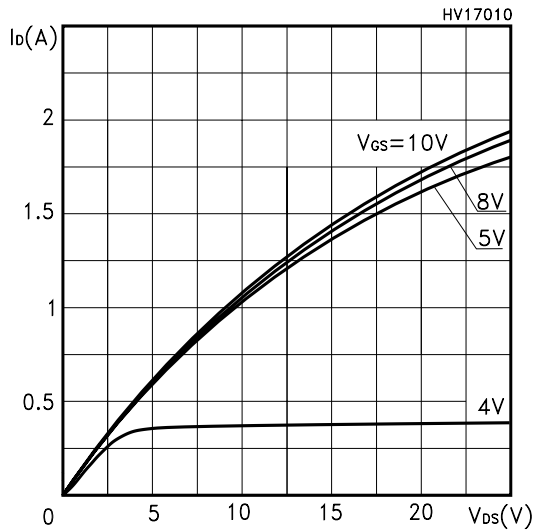

Transfer Characteristics

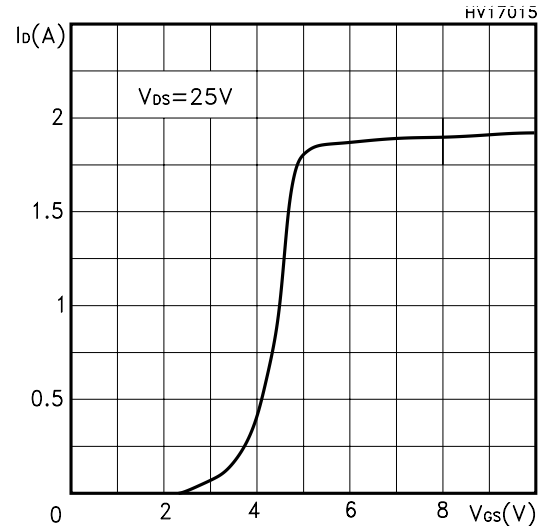

Transconductance

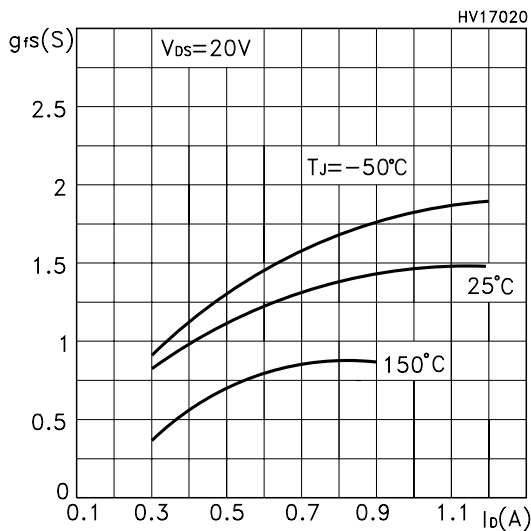

Static Drain-source On Resistance

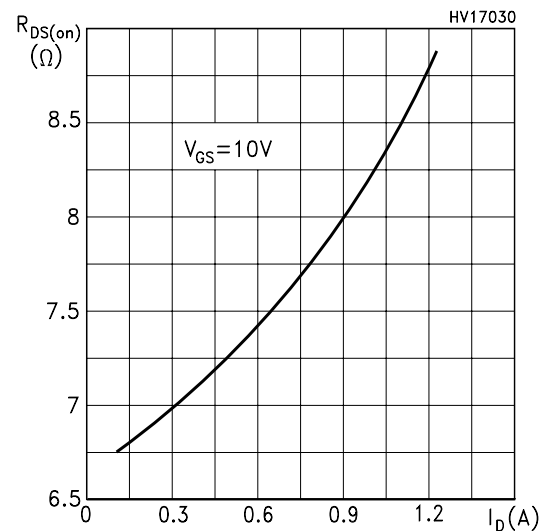

Gate Charge vs Gate-source Voltage

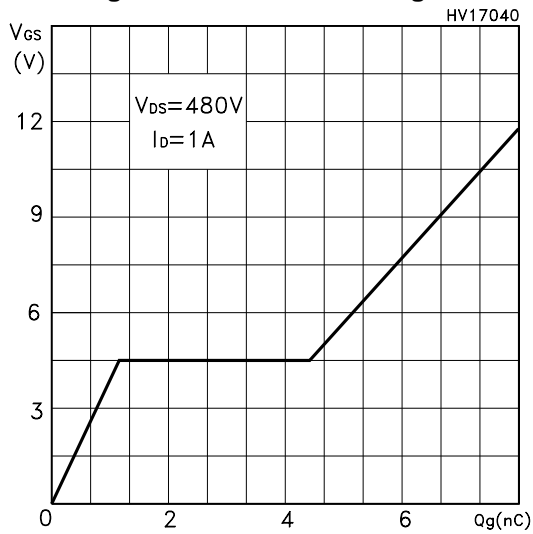

Normalized Gate Threshold Voltage vs Temp.

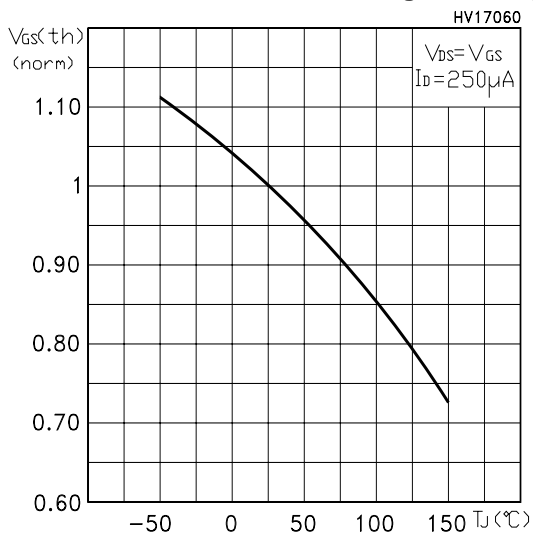

Source-drain Diode Forward Characteristics

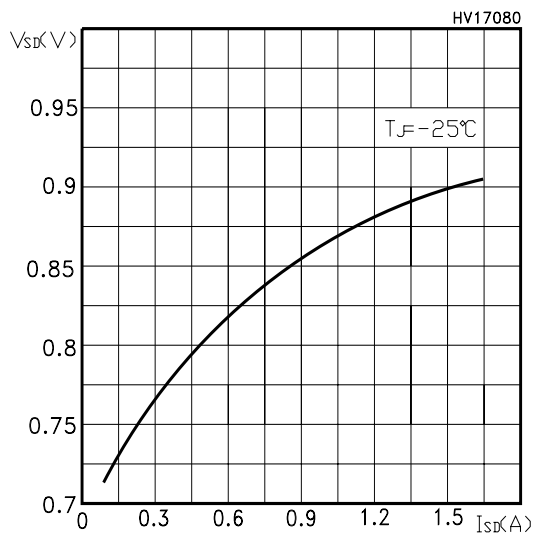

Capacitance Variations

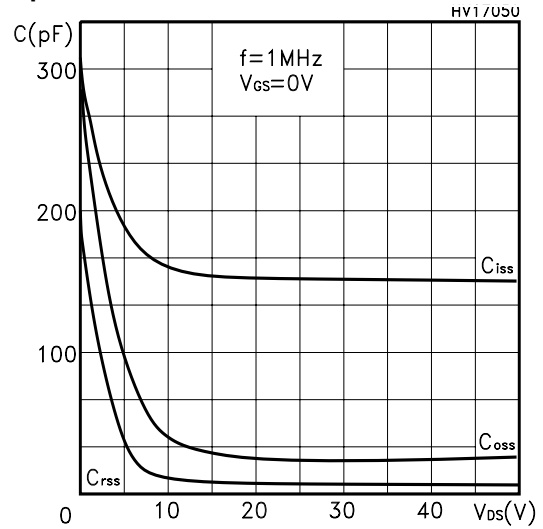

Normalized On Resistance vs Temperature

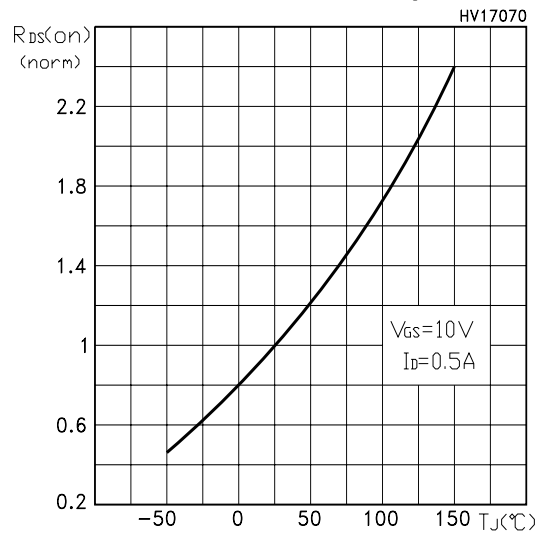

Normalized BVDSS vs Temperature

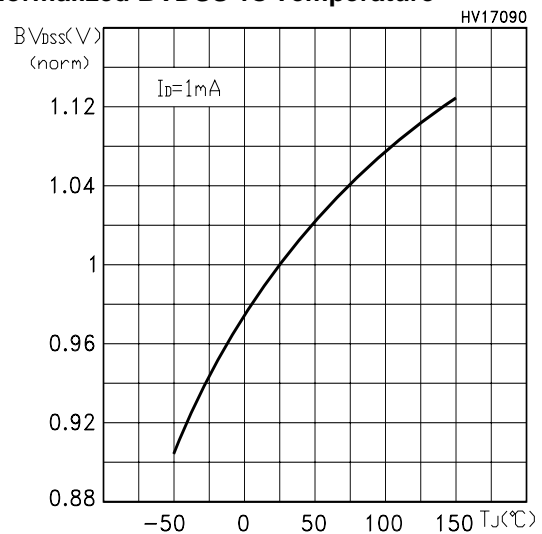

Fig. 1: Unclamped Inductive Load Test Circuit

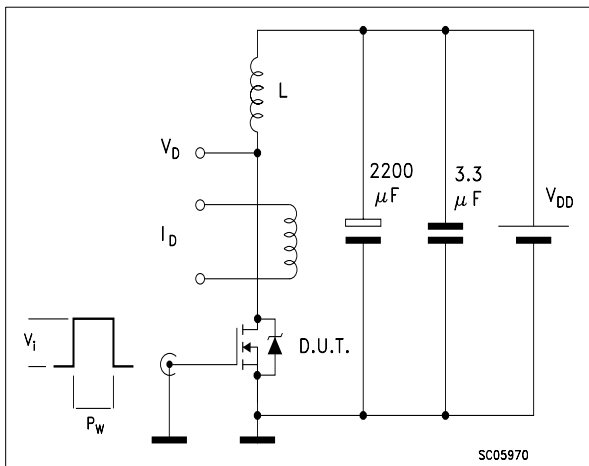

Fig. 2: Unclamped Inductive Waveform

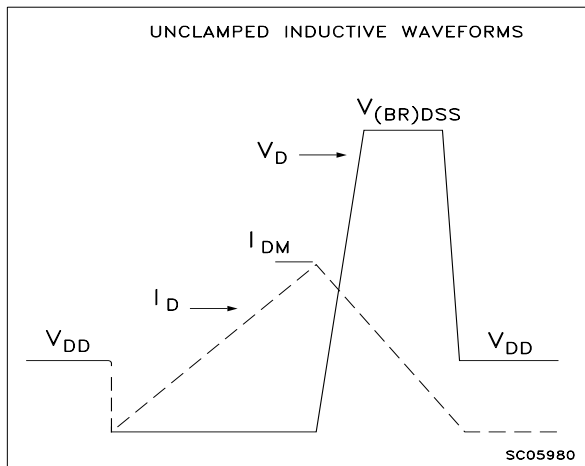

Fig. 3: Switching Times Test Circuit For Resistive Load

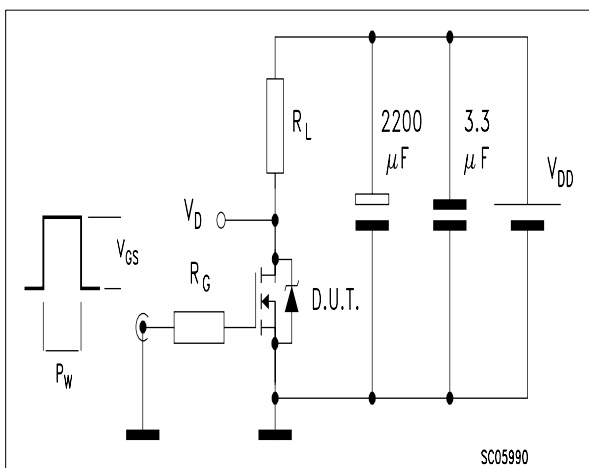

Fig. 4: Gate Charge test Circuit

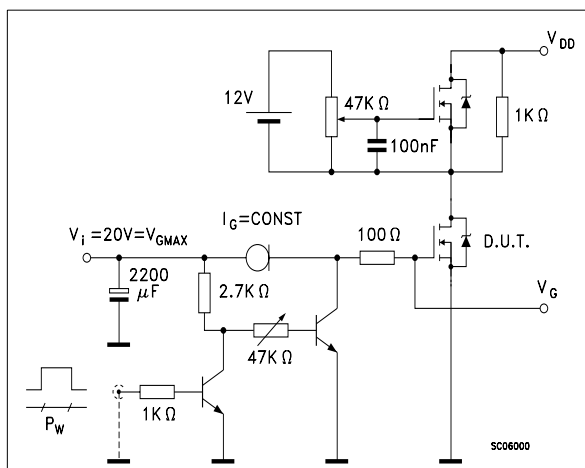
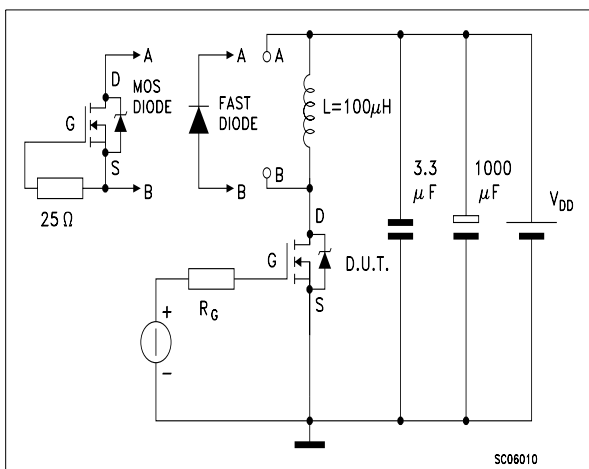
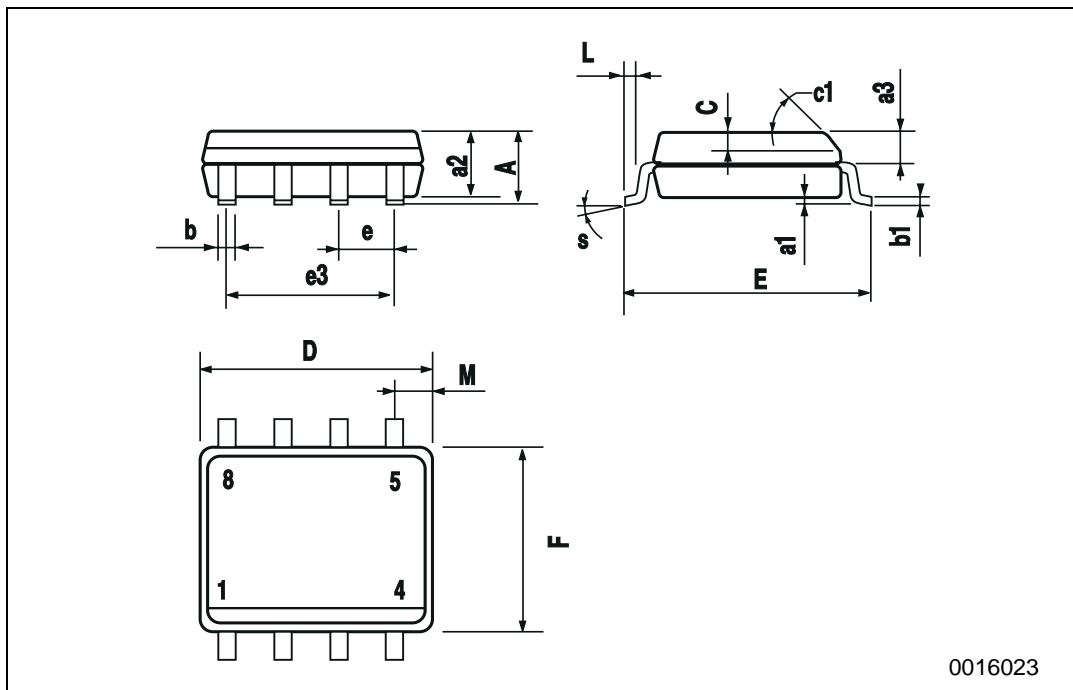

Fig. 5: Test Circuit For Inductive Load Switching And Diode Recovery Times



SO-8 MECHANICAL DATA

DIM.	mm			inch		
	MIN.	TYP.	MAX.	MIN.	TYP.	MAX.
A			1.75			0.068
a1	0.1		0.25	0.003		0.009
a2			1.65			0.064
a3	0.65		0.85	0.025		0.033
b	0.35		0.48	0.013		0.018
b1	0.19		0.25	0.007		0.010
C	0.25		0.5	0.010		0.019
c1	45 (typ.)					
D	4.8		5.0	0.188		0.196
E	5.8		6.2	0.228		0.244
e		1.27			0.050	
e3		3.81			0.150	
F	3.8		4.0	0.14		0.157
L	0.4		1.27	0.015		0.050
M			0.6			0.023
S	8 (max.)					



Information furnished is believed to be accurate and reliable. However, STMicroelectronics assumes no responsibility for the consequences of use of such information nor for any infringement of patents or other rights of third parties which may result from its use. No license is granted by implication or otherwise under any patent or patent rights of STMicroelectronics. Specifications mentioned in this publication are subject to change without notice. This publication supersedes and replaces all information previously supplied. STMicroelectronics products are not authorized for use as critical components in life support devices or systems without express written approval of STMicroelectronics.

© The ST logo is a registered trademark of STMicroelectronics

© 2003 STMicroelectronics - Printed in Italy - All Rights Reserved
STMicroelectronics GROUP OF COMPANIES

Australia - Brazil - Canada - China - Finland - France - Germany - Hong Kong - India - Israel - Italy - Japan - Malaysia - Malta - Morocco
Singapore - Spain - Sweden - Switzerland - United Kingdom - United States.

© <http://www.st.com>